

CERTIFICATION



HACCP International



ISO9001

ICE MATE

by  HOSHIZAKI

SRM-270AB-B-501SA

ICE MAKER

DICE

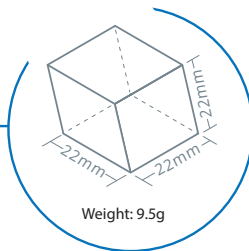

ICEMATE is committed to bringing high-efficiency / energy-saving, and high quality ice-making product to people who have dreams and desire to create their own business with the best scientific technology and manufacturing technology.

KEY FEATURES

SAFETY AND HYGIENE ASSURED ICE MACHINE

AUTO-CLEANING



Timely maintenance of water system can extend life of equipment.

PURE ICE



Overflow self-cleaning function, ensuring ice hygiene

IoT



Slow melt Dilution



Slow Dilution
Slower melting speed due to -7°C of inside temp of ice cube

Powerful Ice Making



Powerful Ice Making

Designed for commercial Ice Machine



High-end Compressor
Stable compressor operation
Machine runs quietly and smoothly

Fast Ice Making
Ice making cycle about 12.0-13.5min

Sufficient Ice Production
Ensuring sufficient ice production in 24 hours

Energy & Water Saving, Quiet Operation



Energy & Water Saving, Quiet Operation

Scientific water cycle system
The water circulation system reasonably utilizes water and reduce waste



Low energy consumption
Long life compressor
Low energy consumption during operation

Noise Reduction
Stable compressor operation
Machine runs quietly and smoothly

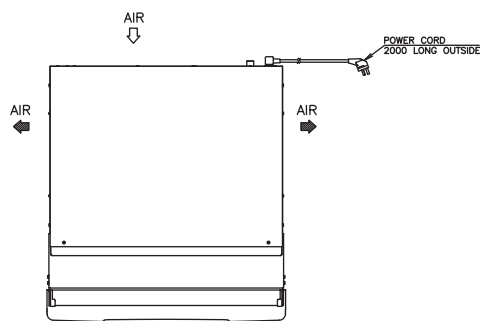

BIN TOP VIEW

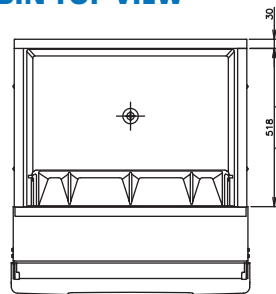

RIGHT SIDE

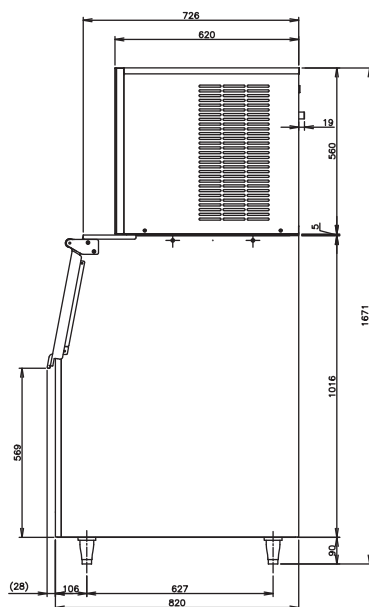

BACK SIDE

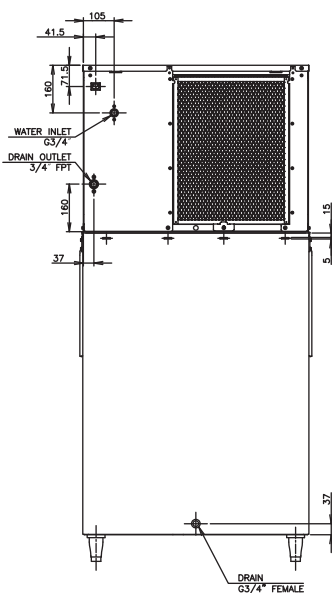

FRONT SIDE

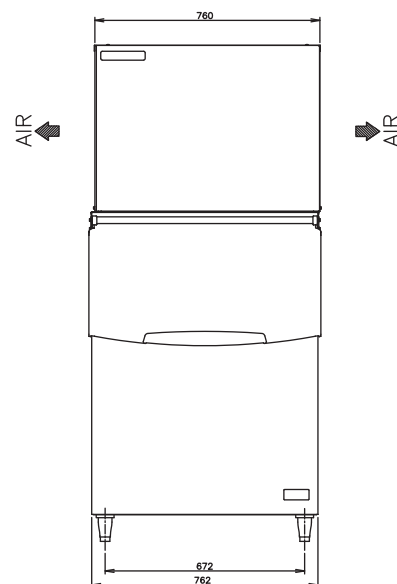

SPECIFICATIONS

| | |
|--------------------------------|----------------------------------------------------------------------------------------------------------|
| Ice Dimensions (W x D x H) | 22 x 22 x 22 mm |
| Outside Dimensions (W x D x H) | 762 x 820 x 1671 (~1701) mm |
| Package Dimensions (W x D x H) | Ice Maker: Pallet+Carton: 850 x 710 x 750mm Storage Bin: 866 x 924 x 1138mm |
| Weight (Net / Gross) | Ice Maker: 59kg / 78kg Storage Bin: 47kg / 57kg |
| Amperage / Starting Amperage | 6.4A/24A |
| Electrical Consumption | (AT32°C / WT21°C) 861W |
| Refrigerant Charge | R404A/620g |
| Ice Storage Capacity | Maximum 217 kg |
| Ice Production per 24H | (AT10°C / WT10°C) Approx. 270 kg (AT21°C / WT15°C) Approx. 225 kg (AT32°C / WT21°C) Approx. 180 kg |

| | |
|----------------------------------|-----------------------------------------------------|
| Water Consumption per 24H | (AT32°C/WT21°C) 0.19m ³ (1.1 L / kg Ice) |
| Ice Production Freeze Cycle Time | (AT21°C/WT15°C) 14.5 min |
| Ice Production per Cycle | (AT21°C/WT15°C) Approx. 2.41kg / 260pcs |

OPERATING CONDITIONS

| | |
|-----------------------|---------------------------------|
| Voltage Range | 198 - 242 V |
| Ambient Temperature | 5 - 38°C |
| Water Supply | 5 - 32°C |
| Water Supply Pressure | 0.07 - 0.55 Mpa (0.7 - 5.5 bar) |
| Supply Voltage | 1/220 - 240V / 50Hz |



HOSHIZAKI

HOSHIZAKI MALAYSIA SDN. BHD.

No. 12, Jalan Penyajak U1/45B. Hicom-Glenmarie Industrial Park, 40150 Shah Alam, Selangor
TEL (+60) 3 5569 8023 | <https://hoshizaki.com.my/>